

A Robotic Manipulator tracking and catching 3D flying objects

Surbhi Kakkad
VIT University, Vellore

Vaibhav Phutane
VIT University, Vellore

Kajal Jaiswal
VIT University, Vellore

Abstract: - This paper elaborates the tracking and catching 3D flying object using a robotic manipulator. For getting the desired output requires to clear these three problems: to predict the trajectory path of the flying object coming towards the manipulator, to find out the catching configuration, and adjust the arm according to that. In this paper, we focus on estimating the possible trajectory paths accessible by the two link robotic manipulator with gripper connected. After the designed trajectory paths are given to the robot arm, the gripper attached to it moves according to that trajectories. (Department of Control and Automation, VIT University, Vellore, India.)

Keywords: - Robot control, catching, Trajectory planning, robot arm, Two link manipulator.

I. INTRODUCTION

We describe the solution for part of the problem of catching the flying 3-D object towards the robot arm. We consider the flying object having a particular shape and mass which will ensure that the center of mass (COM) of the object is at the center only. The three main problems in catching the flying 3-D objects are:

1. Trajectory prediction of flying 3-D object: The trajectories of the flying object are non-linear.

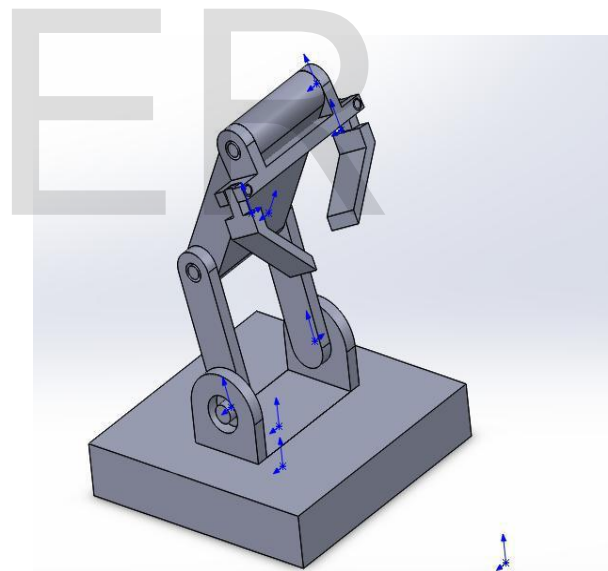

Figure 1. Design of robot in Solidworks

2. Optimal catching configuration: It depends on the intersecting point of trajectories of both flying object and the robot arm.

3. Planning the robot arm motion: the robot arm will go to the intersecting point of two trajectories for catching the flying object.

The robotic arm motion is having particular paths and trajectories. This paths and trajectories are actually the different possible routs or ways that robot arm uses from starting point (standstill condition) to the catching point (intercepting point). Later trajectory estimation consists of design and plan obstacle collision free trajectory from start point to end point.

The softwares used are *Solidworks* and *Matlab*. *Solidworks* is a CAD(Computer aided design) engineering software program used for solid modelling. It is a software introduced by – DS, Dassault system, France. It is compatible for robot modelling. *Matlab* stands for matrix laboratory. It is a software used for exploring and visualizing programs related to areas such as control system , process control , computer applications , image processing etc. We design the two link robotic manipulator arm in *Solidworks* and export that file to *Matlab* for controlling the arm motion according to the designed trajectories. The main aim of this work to present the completesimulation procedure using *Solidworks*, *Matlab*, *Simmechanics* . to test the simulation work we design the two link robotic arm in *Solidworks*.

The robot link specifications are given in the following table1:

LINK	LENGTH OF LINK	JOINT	TYPE OF JOINT
LINK -1	60CM	JOINT - 1	REVOLUTE
LINK -2	60CM	JOINT - 2	REVOLUTE
LINK -3	15CM	JOINT - 3	REVOLUTE
END EFFECTOR	30CM	JOINT - 4	REVOLUTE

2. PROBLEM DEFINITION

To catch the flying objects with different shapes and sizes and it includes 2 major parts. First part is about to design and estimate the maximum possible trajectories of the robot arm and the second part is about to predict the trajectories of the 3D object flying towards the robot. In this paper we concentrate on the first part only.

3. HARDWARE DESIGN OF ROBOTIC SYSTEM

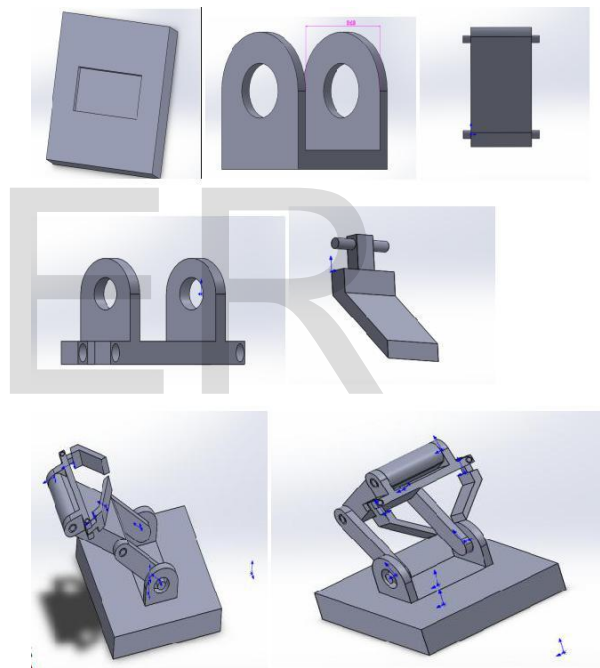

Figure 2. design and assembly of different parts of robot in Solidworks

4. METHEDOLOGY

The work in this paper is related to a 4DOF robotic manipulator. DOF (Degree Of Freedom) is the total number of links in robot. The 4 links in this robot is base, elbow, extension to the

elbow to attach end effector and grabber. The use of the first 3 axes are for positioning the grabber and the fourth axis is for moving the grabber according to the catching point coordinates. There are 4 joints and all are rotary. All the 4 joints are parallel in nature, i.e there z-axes are also parallel, and for parallel z-axes α, d are zero. The DH parameters of the robot are shown in the following table 2:

Joint NO.	d m	θ deg	a m	α deg	Initial value (deg)	Final value (deg)
1	0	variable	0.6	0	0	180
2	0	variable	0.6	0	0	180
3	0	variable	0.15	0	0	180
4	0	variable	0.3	0	0	180

Table 2. DH parameters of robot

Where,

d =joint offset (in meters);

θ = joint angle (in deg);

a =link length(in meters);

α =twist angle(in deg);

These 4 parts are separately designed in solidworks and assembled to get whole design of robot. In this paper the desired task should be completed in two parts. In which the first part is to design the maximum possible trajectories of the robotic arm that can move with the maximum possible paths. The controlling of the robot is done Matlab. The solidworks robot design is imported to matlab using Simmechanics software. We done the Matlab

coding for obtaining the different possible trajectories of the robot, that coding generates a simulink diagram (.slx file) and after we run that file we get the different possible trajectories. The trajectory paths for diffent final value angles for all joints are shown in following pictures:

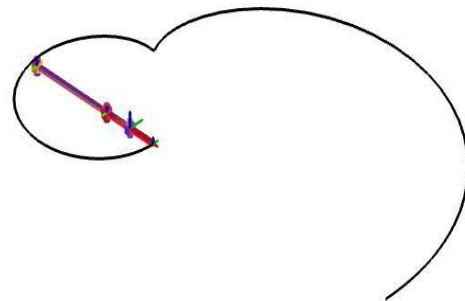

figure 3. Trajectory path of the robot (for 180° final value for all joints)

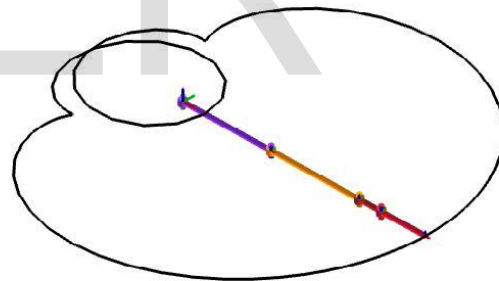

figure 4. Trajectory path of the robot (for 360° final value for all joints)

After the design part in solidworks, that design in imported to matlab for controlling part. The coding in matlab generates a simulink diagram that executes the trajectories of the robot. The simulink dia is:

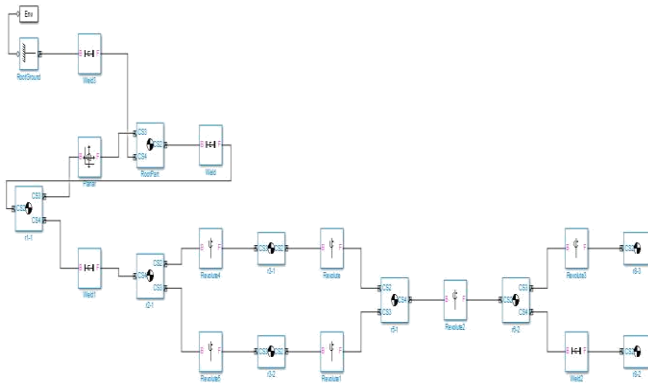

Figure 5. simulink diagram.

There are different type of trajectories are available. In which first we applied for cubic trajectory and obtained the graphs for position, velocity and acceleration for each of the 4 joints. The graphs of position, velocity and acceleration of joint 1 are shown below:

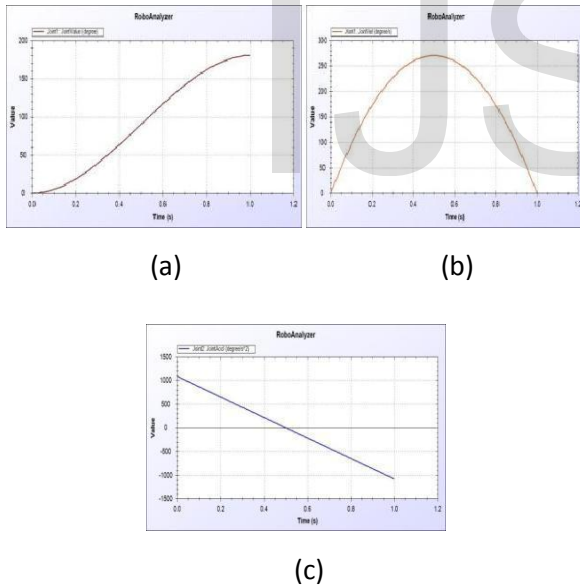

Figure 6. (a)position; (b)velocity; (c)acceleration of cubic trajectory for joint 1.

For cubic trajectory, the position and velocity graphs are continuous but the acceleration graph is discontinuous which can lead to sudden jerk. This can damage the robot joints and links. So, we moved to another trajectory that is quantic trajectory. The

graphs of position , velocity and acceleration when applied for quantic trajectory are shown below:

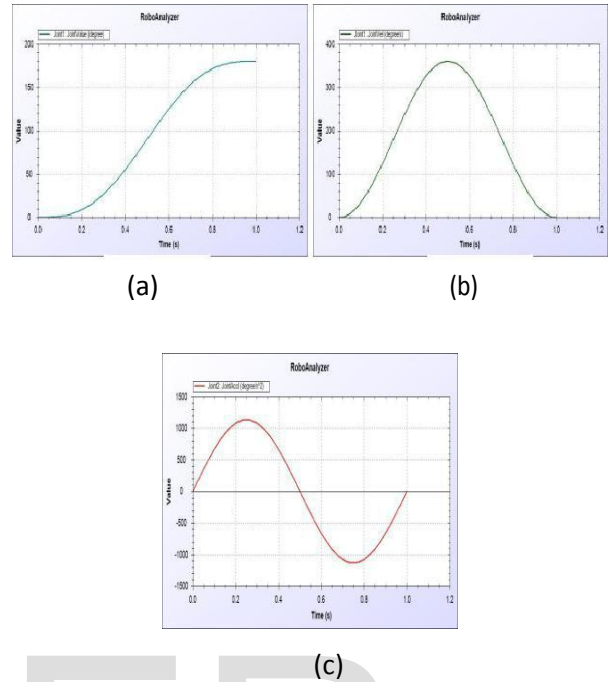

Figure 7. (a)position; (b)velocity; (c)acceleration of quantic trajectory for joint 1.

For quantic trajectory the posion and velocity are continuous as in cubic but also the acceleration in quantic trajectory is continuous which is desired.

5. CONCLUSION AND FUTURE SCOPE

We gained knowledge of several lessons during this project work. We grasp a good command over solidworks and matlab. Here, we have used very simple robot links and gripper so that it can be easily controlled by matlab.

For future scope this methodology can be applied for industrial application like pick and place, assembling parts,etc. Hence the predicting object trajectory and catching configuration can be considered as future work.

6. REFERENCES

Kang, Jin-Young
Choi",IEEE,Volume:35,ISSUE:6,2005.

- [1] Seungsu Kim, Ashwini Shukla, And Aude Billard "Catching Objects in Flight" IEEE Transactions on Robotics, VOL.30,NO.5,October2014.
- [2] Gianetan sing sekhon , Kartik Sharma"Design & Development of Ball Catching Robotic Arm",IJRTE,ISSN:2277-3878,Volume-1,Issue-3, August 2012.
- [3] Vishnu R. Kale, V.A. Kulkarani,"Object Sorting System Using Robotic Arm",IJAREEIE,ISSN:2278-8875,Volume 2, Issue 7,July 2013.
- [4]"Review on An Object Following Wireless Robot ", Tushar Takalkar, Prabhaldeep Das, Rahul Verma, Gaurav Vishwakarma, IJRET, eISSN:2319-1163,Volume:3,Issue:04,APR 2014
- [5] A Project Report on "Intelligent Robotic Arm", submitted to Innovation cell , IIT Bombay.
- [6] "Online robot trajectory planning for catching a moving object", Lin Z. Zeman v, Patel RV,IEEE,ISBN:081619384,Volume:3,may 1989.
- [7] S M Khansari Zadeh and A.Billard, "Learning stable non linear dynamical system with guassian mixture models," IEEE Trans Robot,Volume:27,no.5,pp43-957,oct.2011.
- [8] "Trajectory planning and motion control of a two armed robot",Ching-chih Tsai, Ting-Ting Liang, Yi-Yu Li,IEEE, ISBN-97814244476428, Aug 2010.
- [9] "A geometric model of the trajectory planning for the robot's arm", Chernavsky, A.V.Karpushkin, V.N,IEEE,Volume:2, 1992.
- [10] "Online trajectory planning of robot arms for interceptions of fast maneuvering object under torque and velocity constraints", Dongkyoung Chwa, Junho